

# Sampling PIT-tagged Juvenile Salmonids Migrating in The Columbia River Estuary, 2008

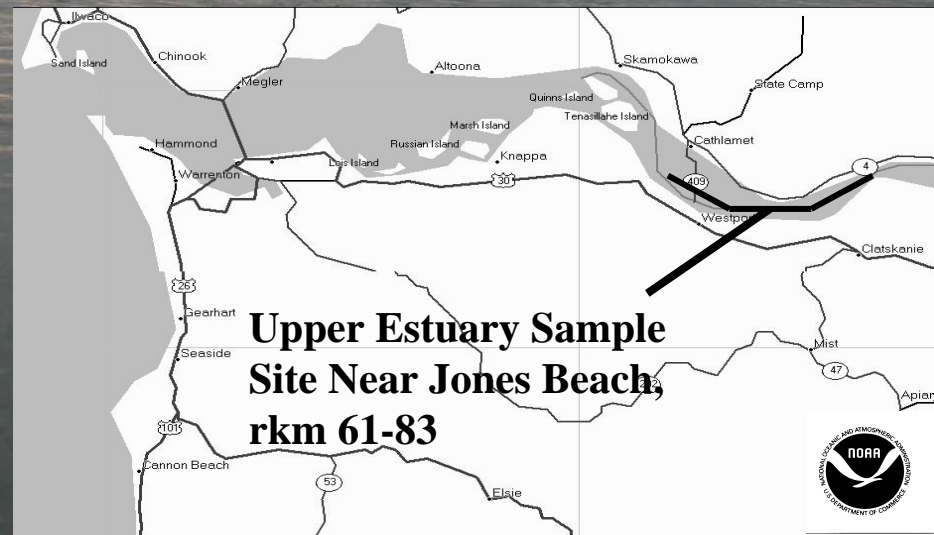

**Richard D. Ledgerwood, NOAA Fisheries**  
**Robert J. Magie, PSMFC**  
**Matthew S. Morris, PSMFC**



## Objectives

- Continue development of a magnitude larger and more efficient antenna system.
- Estimate survival through the Columbia River hydropower system for PIT-tagged salmonids during April-June.
- Contribute data to multi-year analysis for survival and migration timing for PIT-tagged salmonids.
- Sample for subyearling fall Chinook salmon in the summer/fall/winter 2008.

# Columbia Basin PIT Tags

Columbia Basin PIT tag Releases and Detections at Bonneville Dam and Jones Beach (Rkm 75)

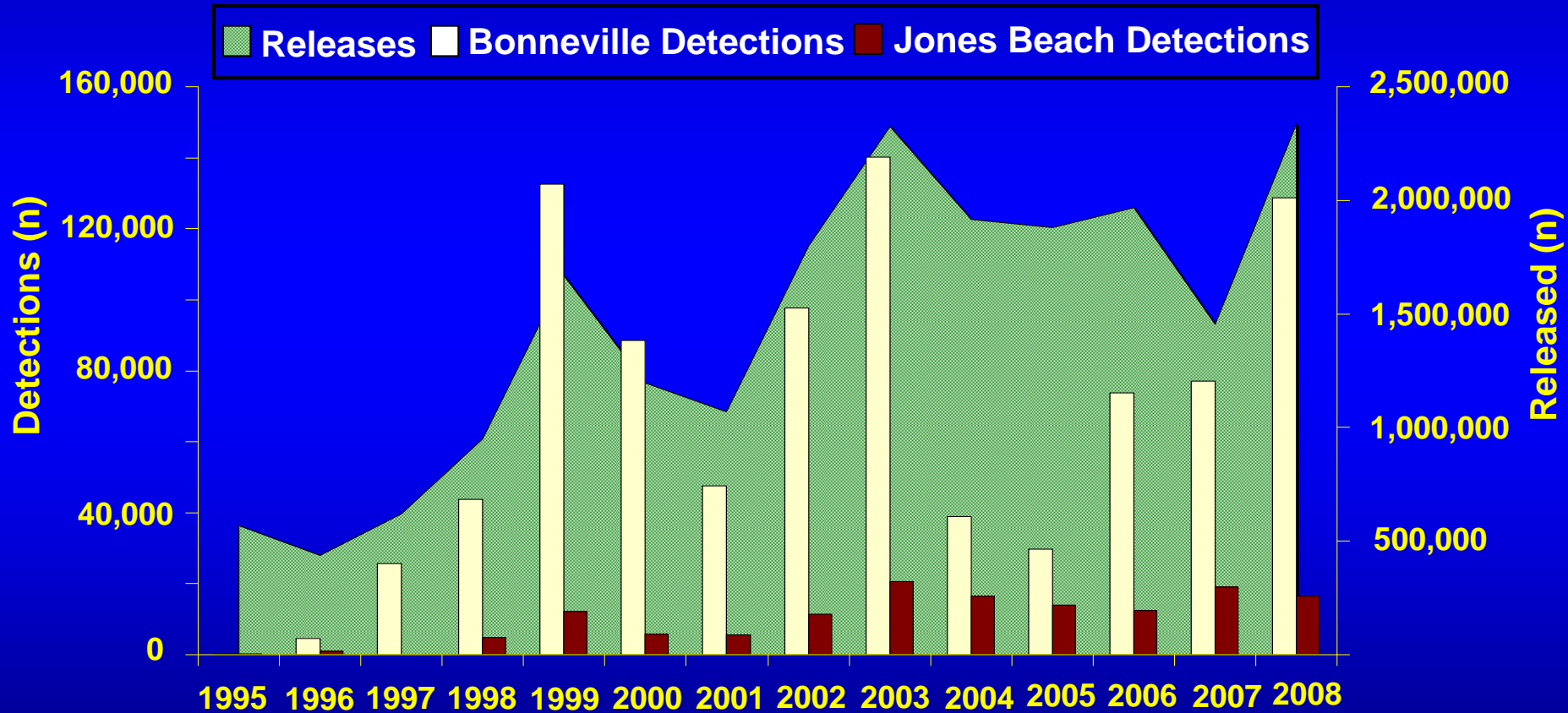

# Pair-Trawl PIT Tag (Electric Barge) Antenna Used in Early 2008

Fish passage tunnel

Front and rear coils  
for dual detections



# Matrix Pair-Trawl PIT Tag Antenna Used in 2088

Fish passage tunnel

Front and rear coils  
for dual detections

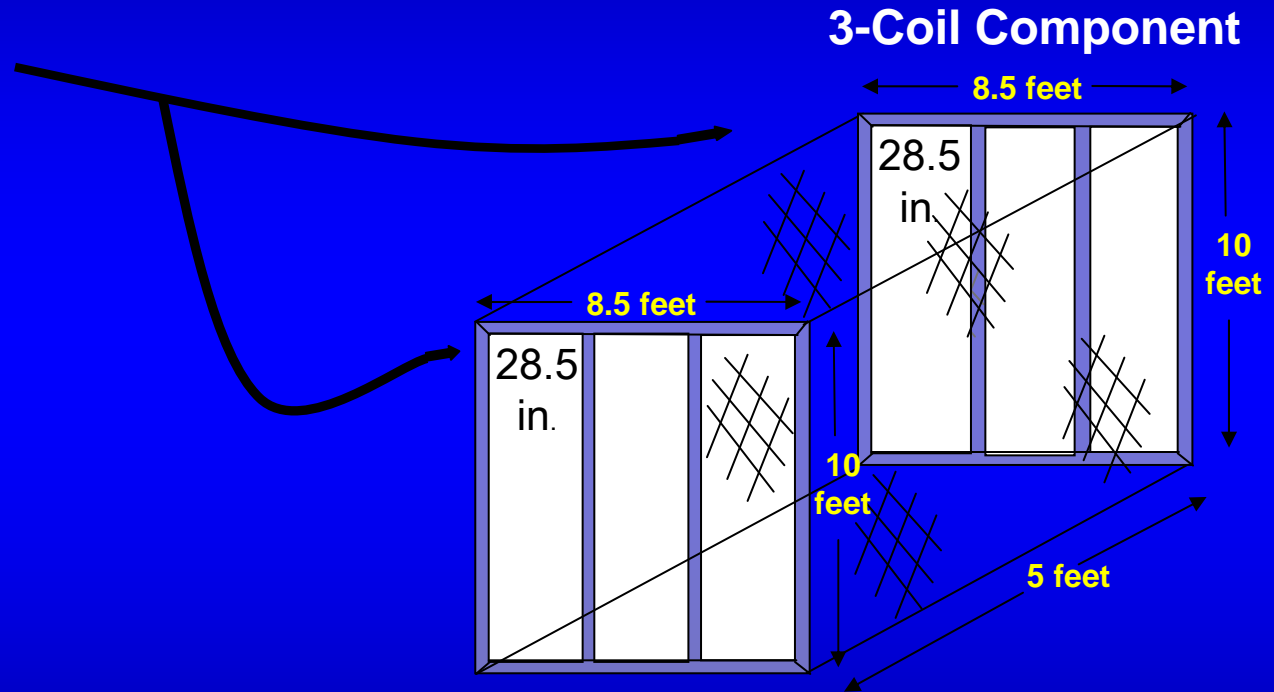

3-Coil Component

# Matrix Antenna Deployment Front and Rear components (3-coils each)

Pre-Deployment

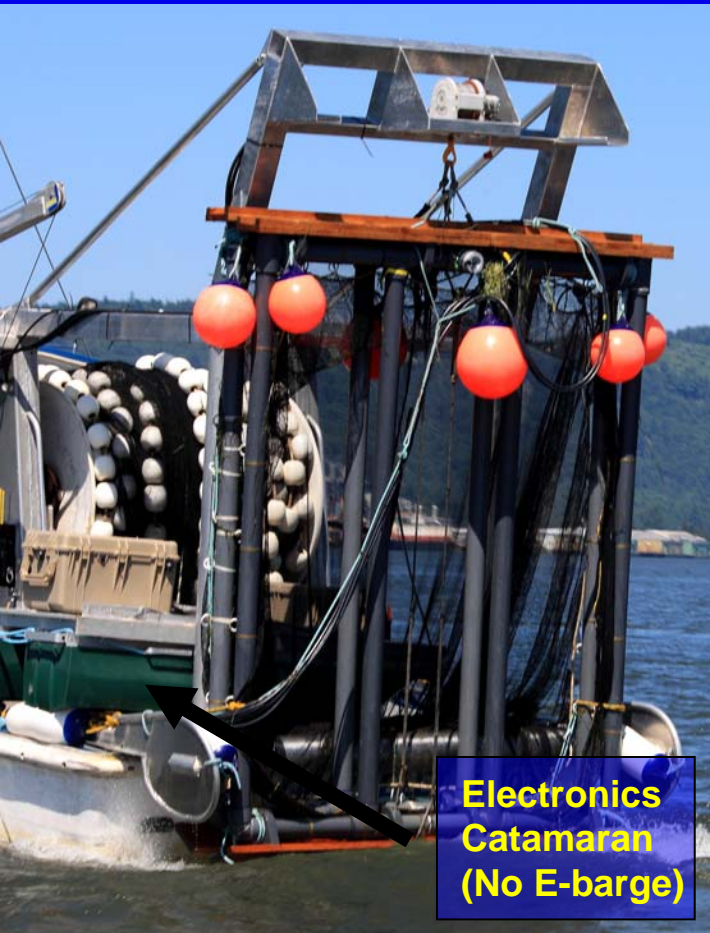

Matrix antenna under tow

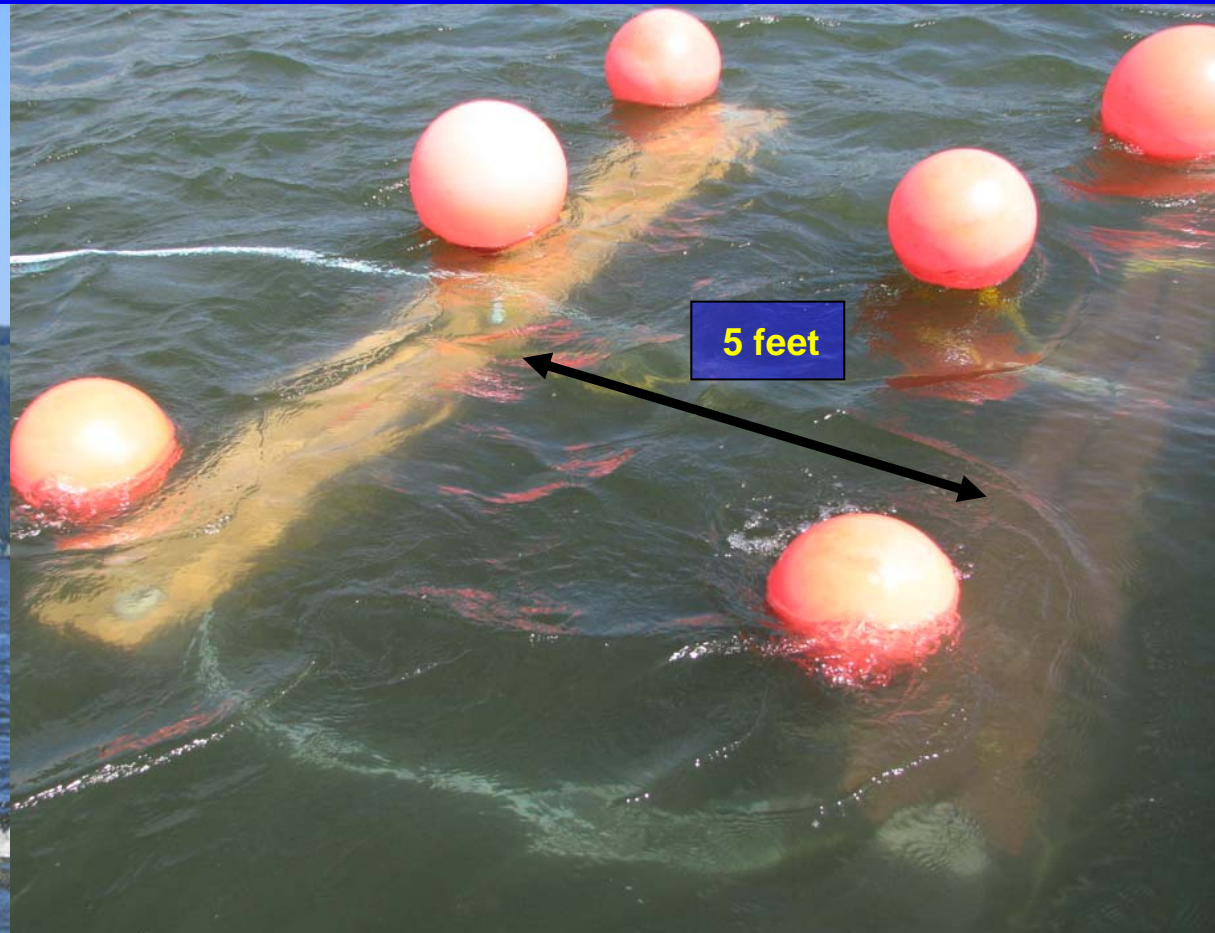

# 2008 Matrix vs. Electric Barge System Tandem Sampling Results

**Matrix System** - Detections (n) = 716  
**Electric Barge System** - Detections (n) = 340

Tandem Sample = 14.37hrs

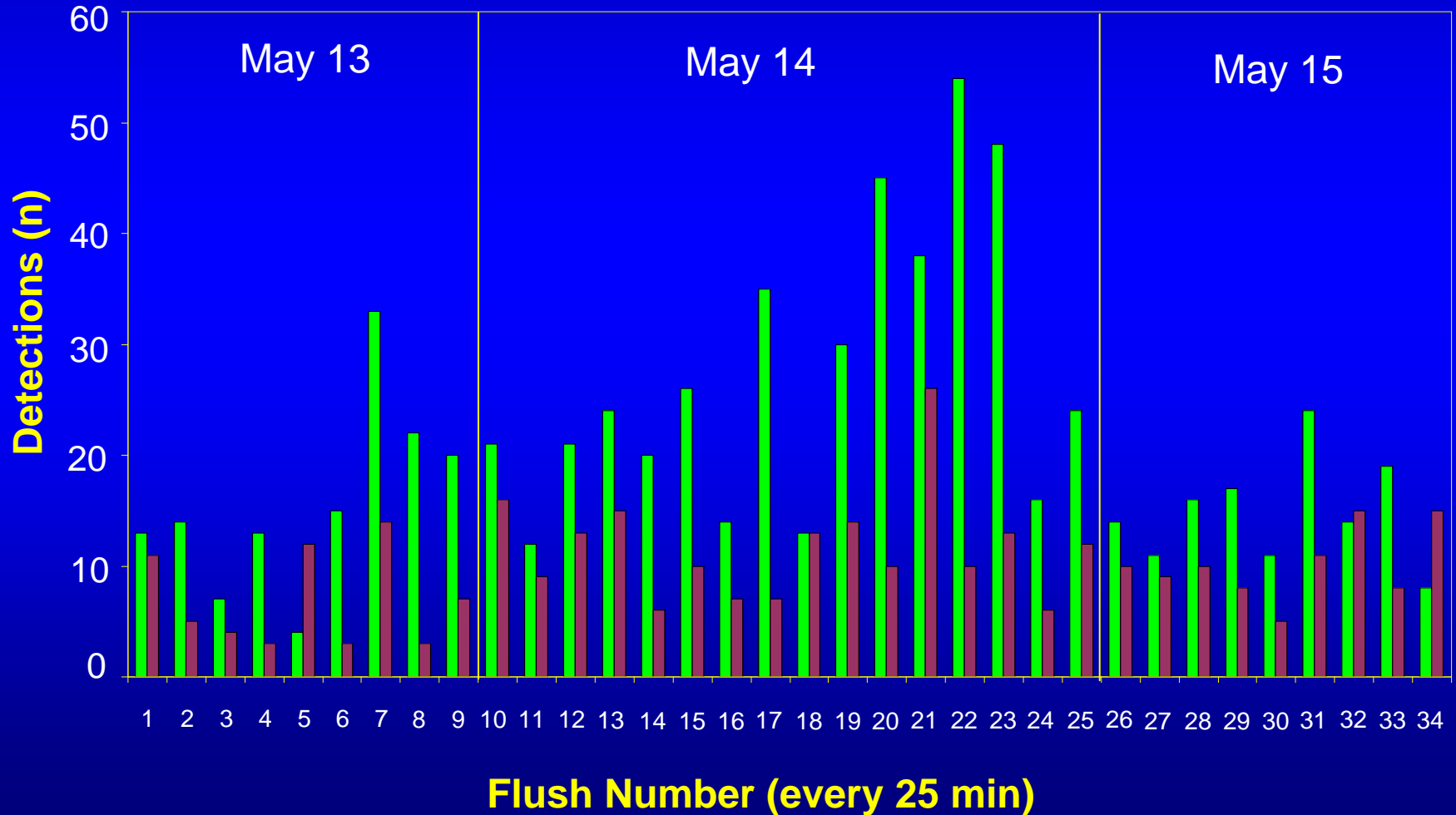

# Daily Sample Effort at Rkm 75

- Electric Barge System (201 hrs)
- Matrix Pair Trawl System (774 hrs)

2 Crew Sampling Period  
Mean = 12 hours

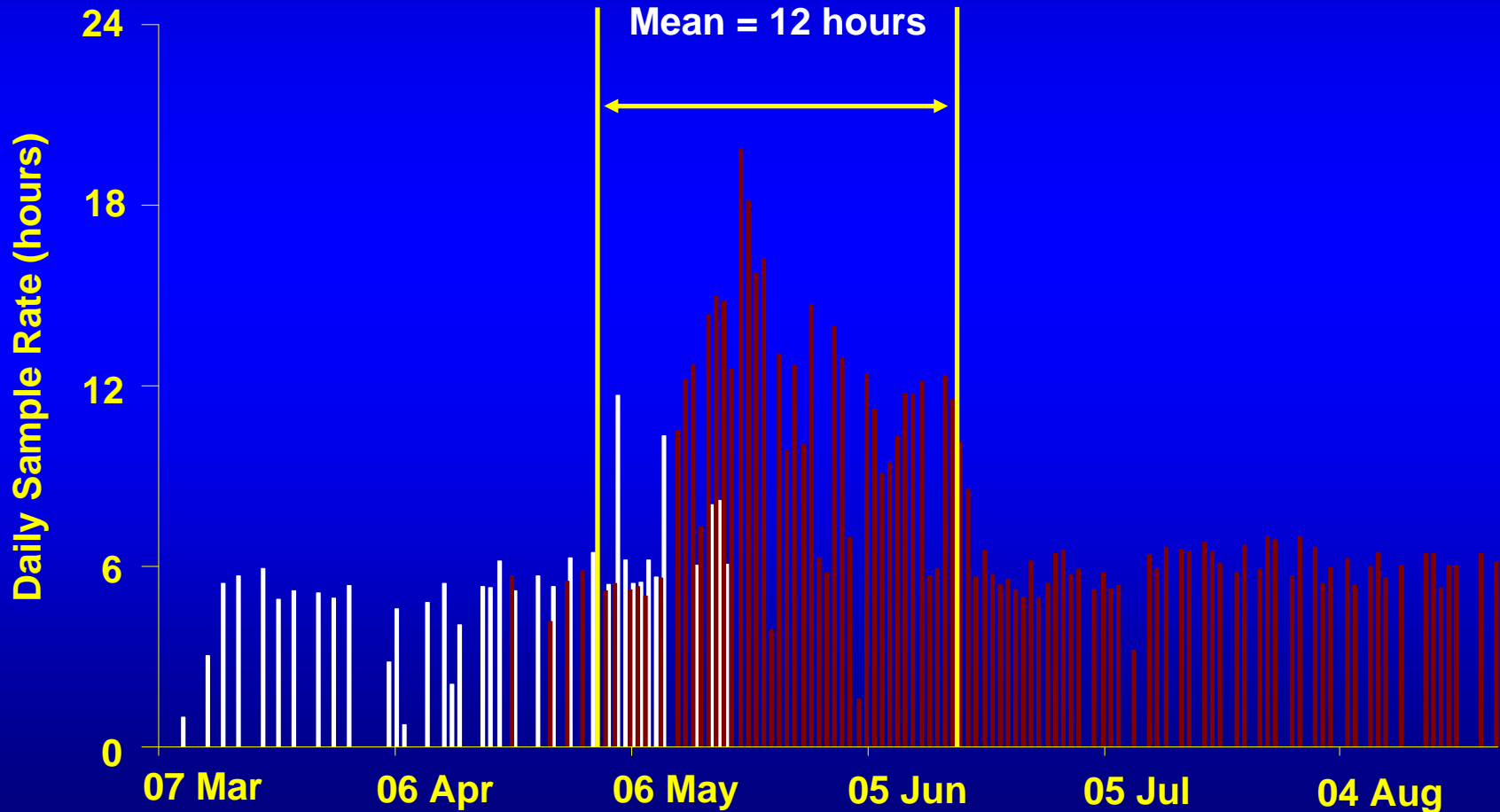

# Pair Trawl Detections 2008

Species/run	Hat.	Wild	Unk.	Total
Spring/summer Chinook salmon	6,171	1,051	175	7,397
Fall Chinook salmon	2,656	39	39	2,735
Coho salmon	287	4	0	291
Steelhead	4,205	1,580	165	5,950
Sockeye	87	0	35	122
Cutthroat	0	0	0	0
Unknown	0	0	68	68
<b>Grand total</b>	<b>13,407</b>	<b>2,661</b>	<b>506</b>	<b>16,563</b>

Source of Juveniles Detected  
in the Estuary 2007  
n=16,563

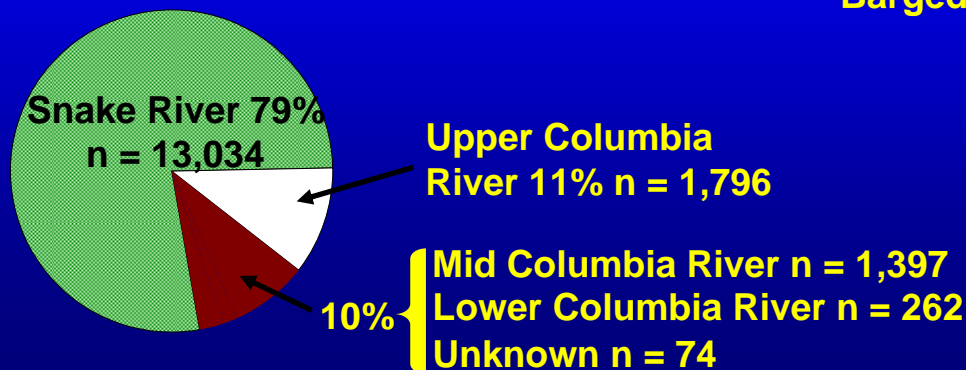

History of Juvenile Salmonids  
Detected in the Estuary  
n=16,563

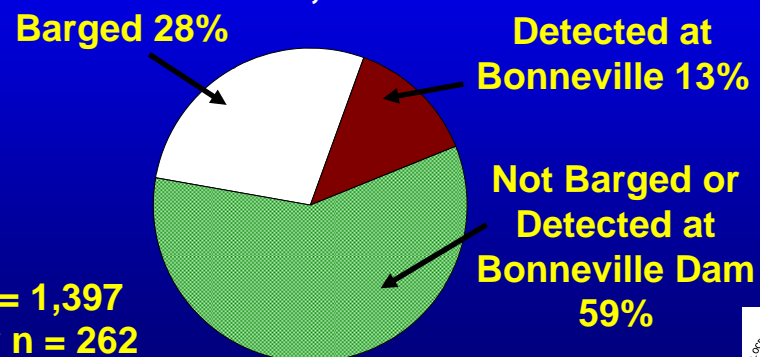

# Estuary Detections Pit Tagged Fish Previously Detected at Bonneville Dam

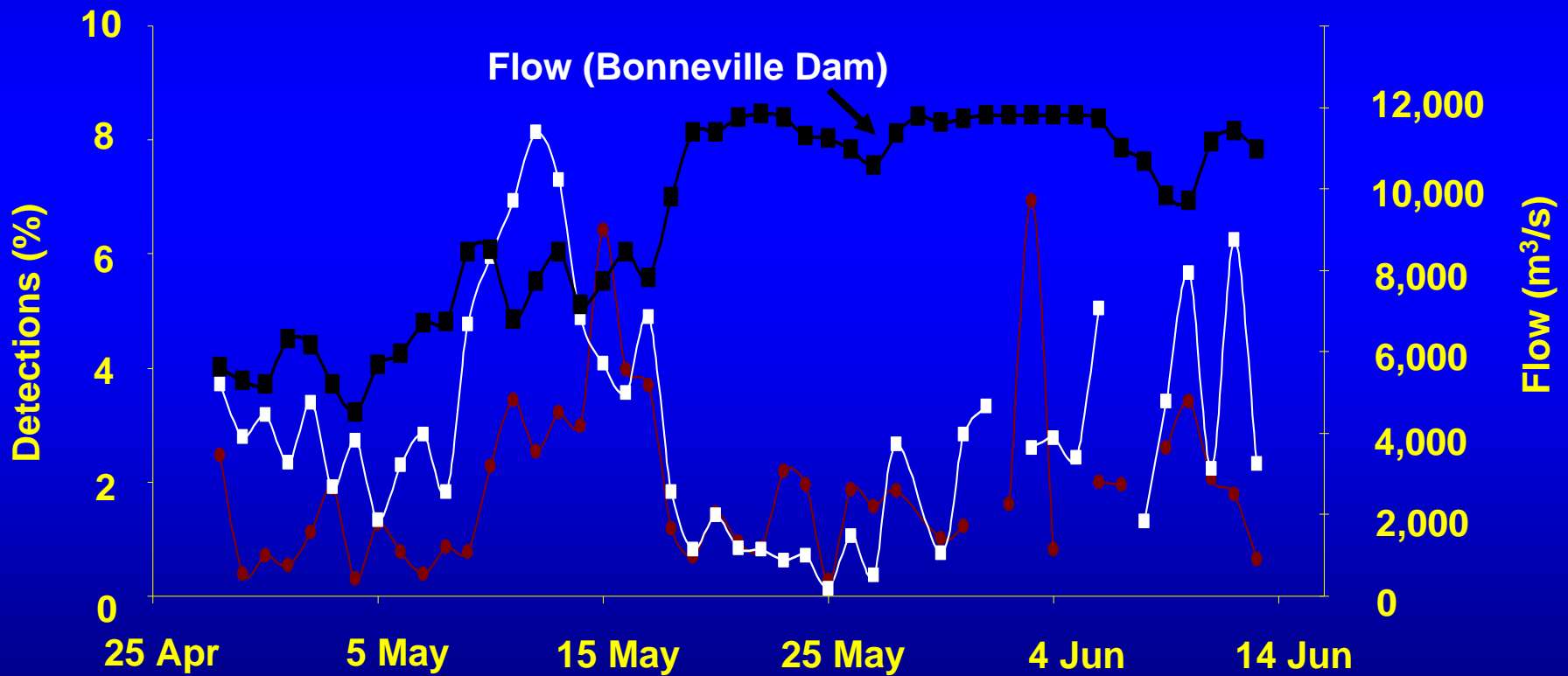
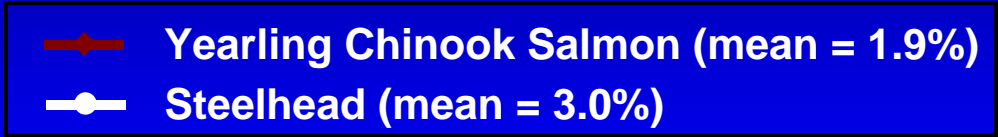

# Pair Trawl Mean Hourly Detections

## Yearling Chinook Salmon

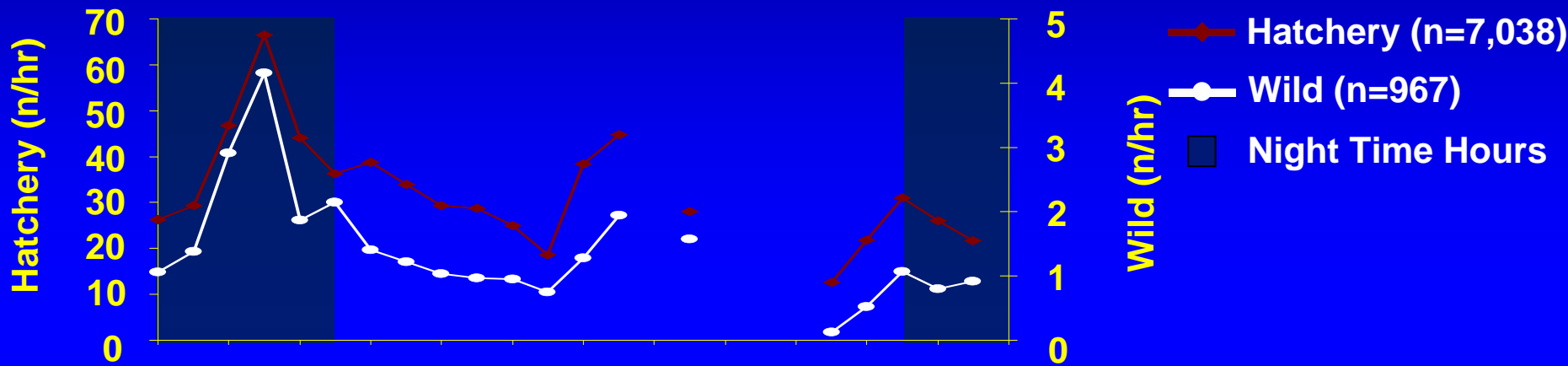

## Steelhead

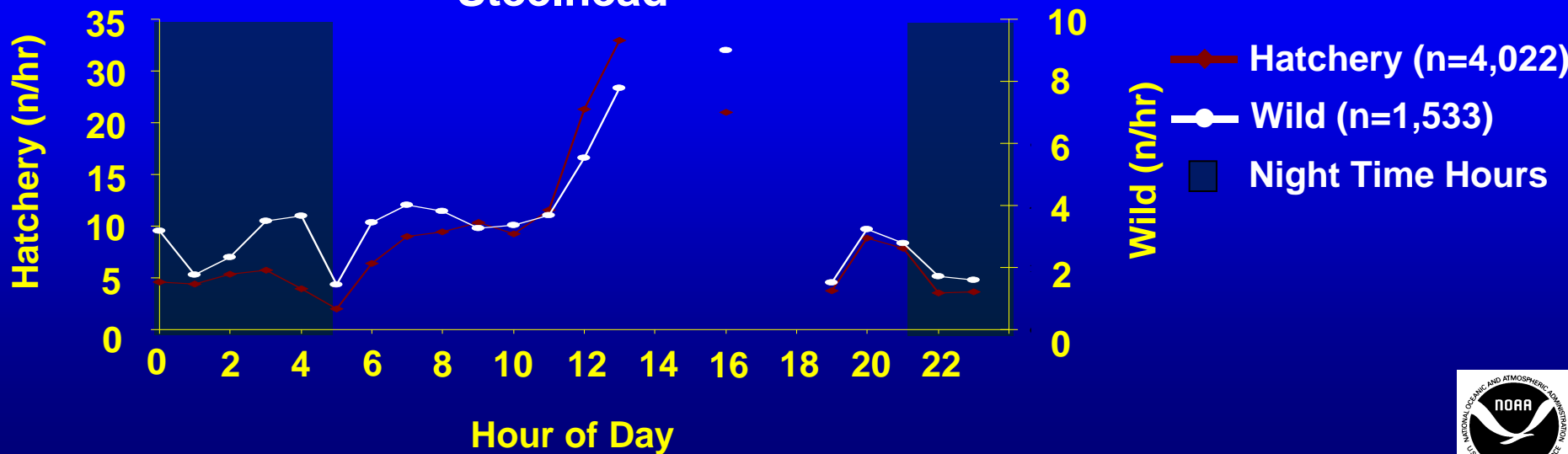

# Travel Speed From Bonneville Dam to the Estuary for Yearling Chinook Salmon

- ◆ In-River n= 513 (Detected at Bonneville Dam)
- Barged n= 1,817 (Released Below Bonneville Dam)

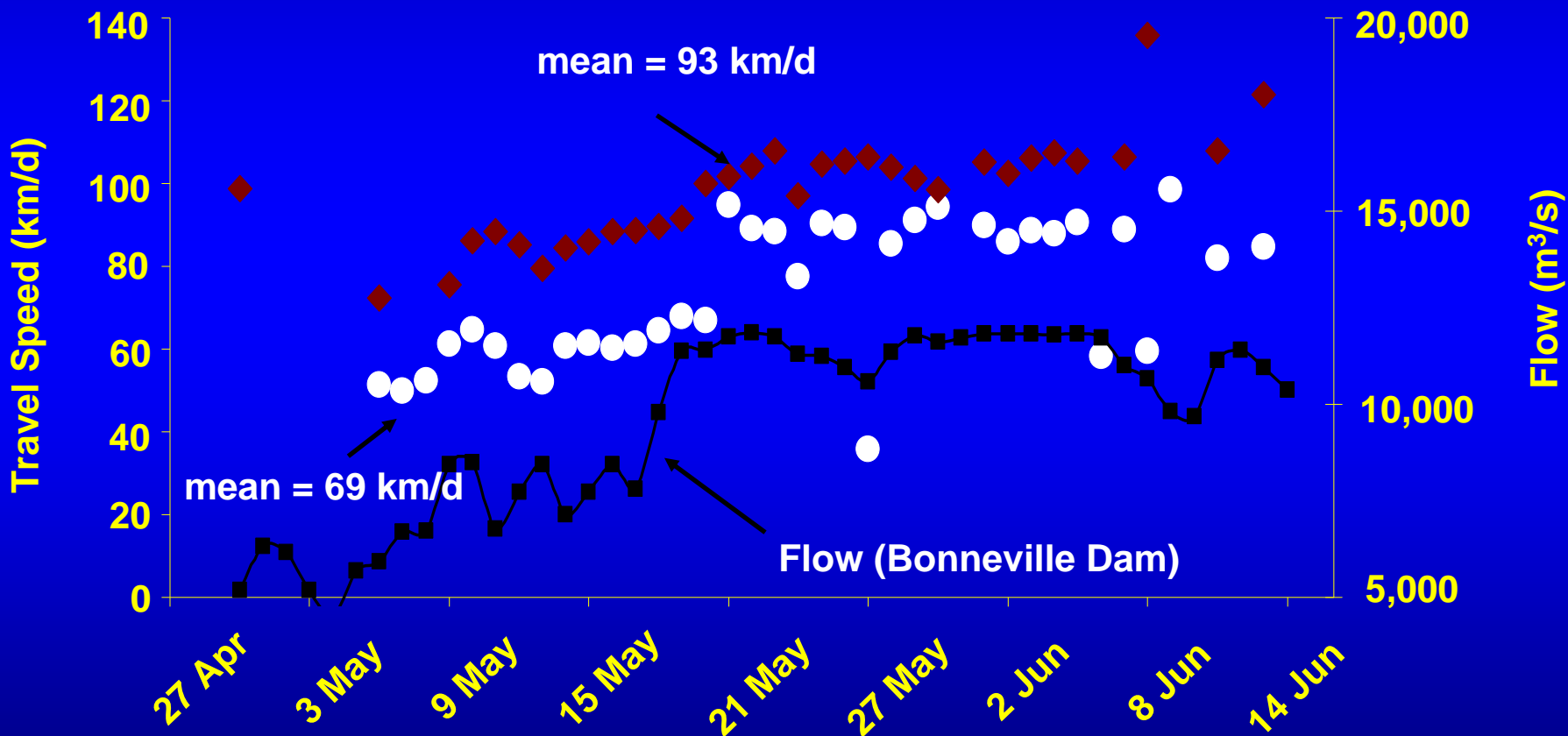

# Survival (SE) from McNary to Bonneville Dam

## Yearling Chinook salmon

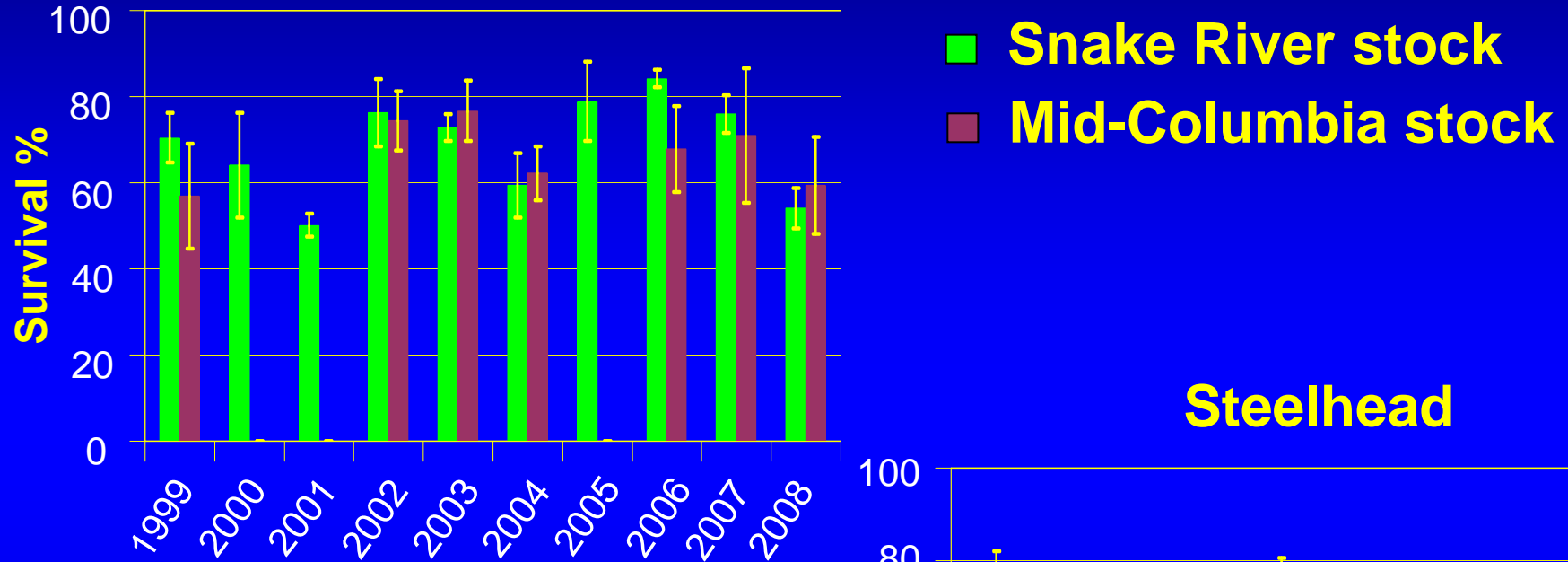

Seasonal weighted  
Averages from weekly  
estimates

## Steelhead

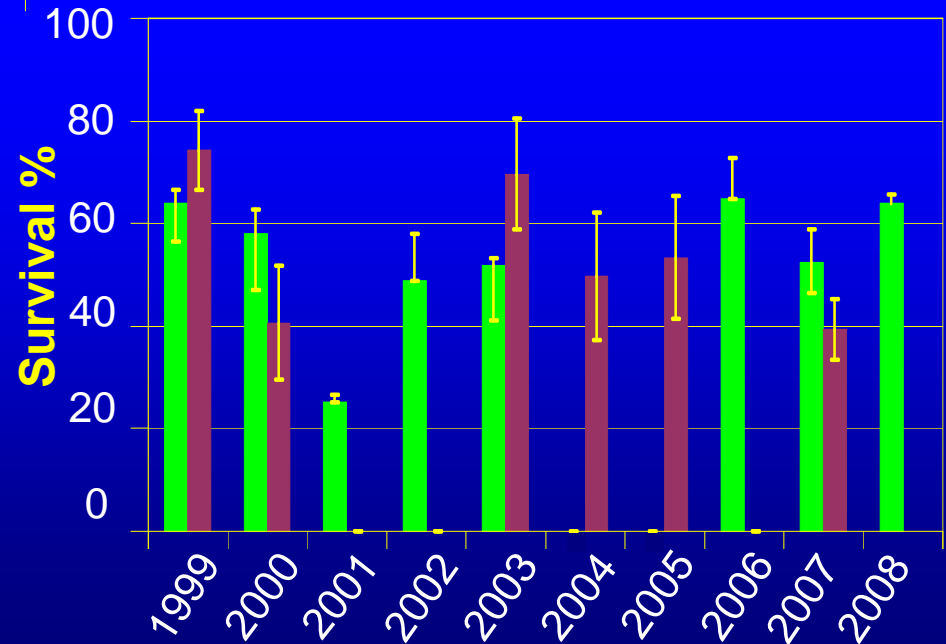

# Daily Travel Time Subyearling Chinook Salmon By Basin

● Snake River Source  
● Little White Salmon and Spring Creek Hatcheries

● = 1 fish   ● = 5 fish   ● = 10 fish   ● = 20 fish   ● = 40 fish

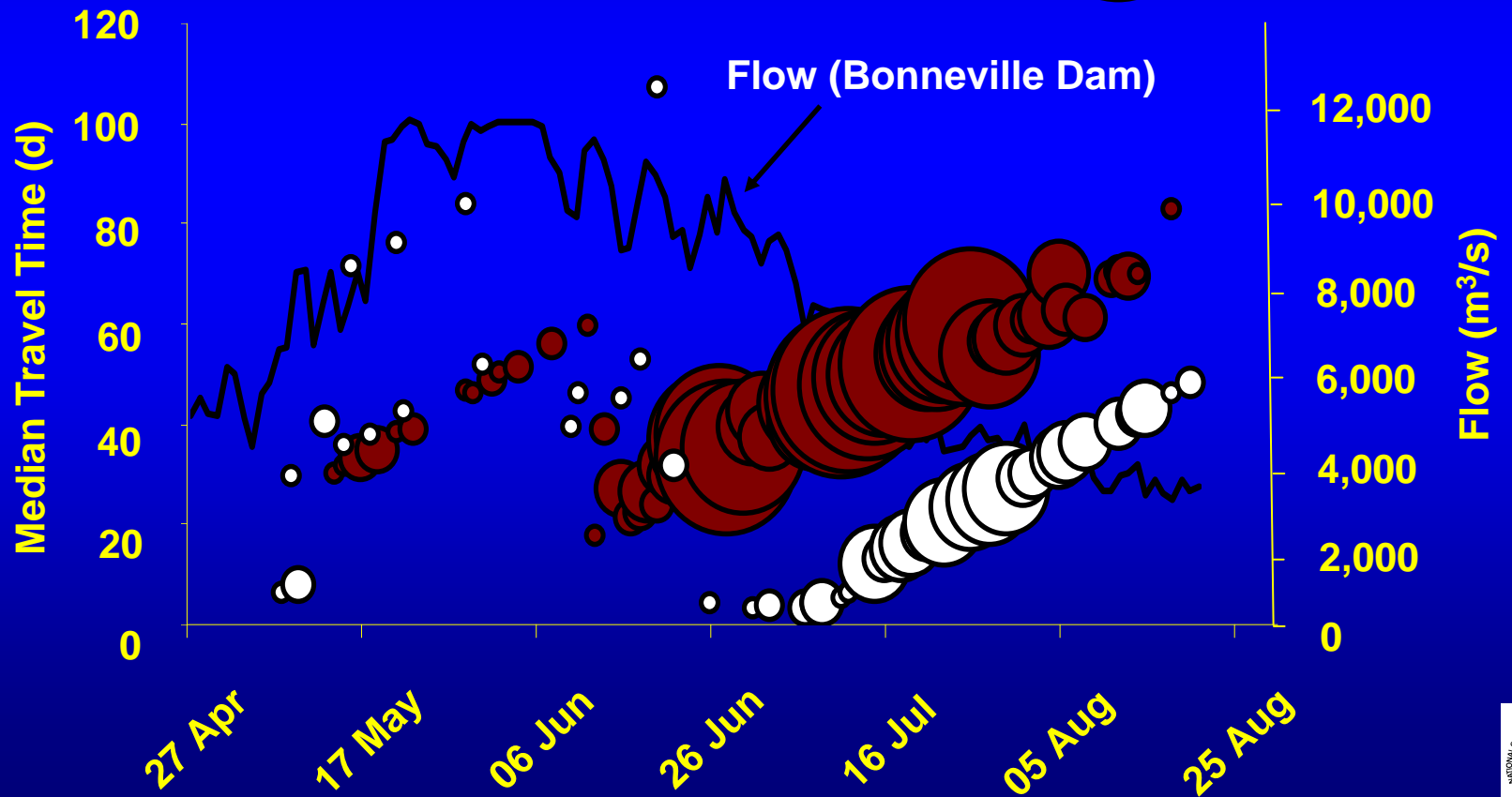

# Fall Sampling for Subyearling Chinook

(29 September – 30 October)

## Matrix (35 Hours, 2 Detections)

Subyearling Fall Chinook (66 mm)

Released from Little White Salmon Hatchery on 3 July

Travel time to RKM 75 = 103 days

Subyearling Chinook (105 mm)

Released into the McKenzie River on 9 September

Travel time to RKM 75 = 54 days

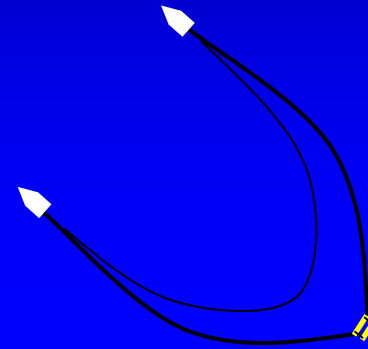

## Shoreline (24 Hours, 1 Detection)

Chinook (163 mm)

Tagged and transported from Lower Granite Dam on 10 Oct

Travel time to RKM 75 = 5 days

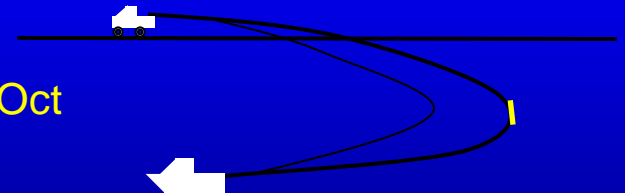

# 2008 Summary

- Matrix antenna system was tested and proved to be twice as Efficient as the Electric Barge system at detecting PIT-tagged fish
- High river flows and debris in late May and June resulted in reduced efficiency and faster PIT-tagged fish travel time
- Survival from McNary Dam to Bonneville Dam was lower for yearling Chinook than in 2007 but higher for steelhead
- Fall sampling (59 hours in October) resulted in three detections of PIT-tagged fish

# Prototype Matrix Separation By Code System

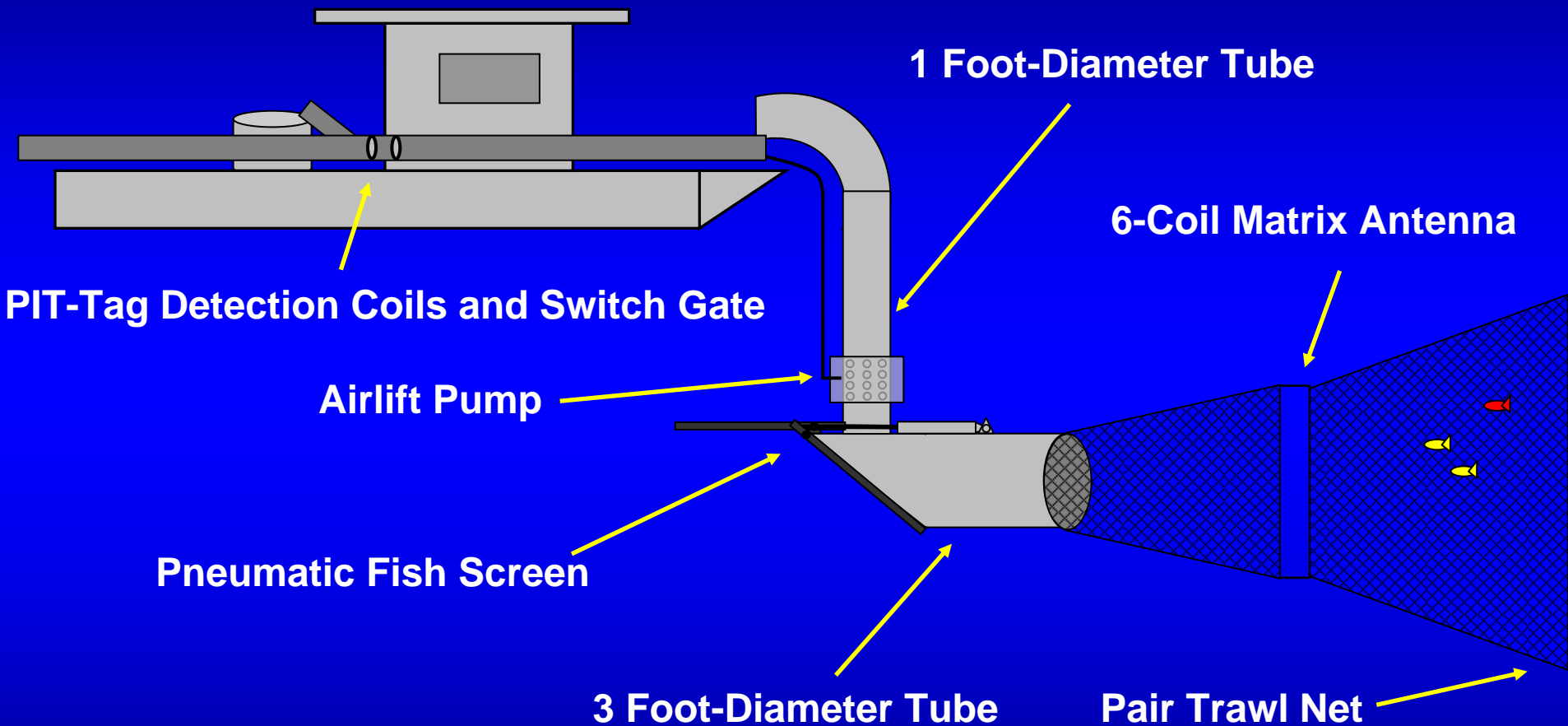

# Acknowledgments



Scott Dunmire, Corps  
John Piccininni, BPA  
Ben Sandford, NOAA  
Hal Campbell, NOAA  
Rick Martinson, PSMFC  
Terry Roe, PSMFC  
Brian Kelly, PSMFC  
Jim Simonson, NOAA  
Rest of the 2008 Crew

